



## Effective Power Module WLM-3



### Technical data:

Power supply WLM-3:	+/- 15V
Required voltage & current of the WLM-3 without sensors:	+15V: 50mA -15V: 50mA
Required current for current sensor:	10mA (only for +15V)
Power supply of each current (Hall) sensor:	+8V (at WLM-3)
Temperature range:	+5°C to +70°C
Measurement dynamic:	0dB (1 : 3000)
Sensitivity: and	See the table current (Hall) sensors formulas to convert into Watt
Cable to Tool Monitor:	3x0,25mm <sup>2</sup> plus screen (not included in delivery, length: max 100m)
Cable of current (Hall) sensor:	3x0,25mm <sup>2</sup> plus screen for 0V 2m included in delivery (extra length on request)

### Casing of WLM-3:

Weight:	180g (without current (Hall) sensors)
Degree of protection:	IP50
Dimensions (W x H x D):	55 x 75 x 110 mm
Design:	For installation in electric cabinet on standard (norm) rail DIN 46277 and DIN EN 50022

- Single phase- and 3-Phase-Measurement
- Installation in electrical cabinet on standard rail
- Logarithmic and linear output for effective power (up from serial number 30.001 both outputs on external clamp)

### Set-up and function:

The WLM-3 is a highly sensitive and fast reacting effective power measurement unit.

The system consists of 3 current sensors, that are based on the Hall effect, and a measurement unit called WLM-3. It is made for electrical cabinet use.

# Diagram WLM-3

## Settings:



In case that the power curve on the Tool Monitor is too wide or rough, you should increase the smoothing on this trimmer (if this roughness is not used to detect mistakes in the process). You have the maximum smoothing amplification after 25 revolutions (clockwise direction).



Amplifies small displayed measurements of the **logarithmic output P<sub>out</sub>log**. The amplification gets lower with an increasing measurement, s. drawing. You have the maximum amplification after 25 revolutions (clockwise direction)

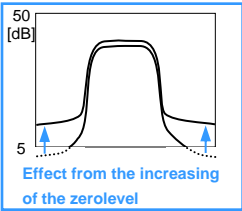

### Terminal 16

+24 (17-38)V AC/DC for taring on the idle power before every cut. **Only for logarithmic output (Terminal 11)**. For more explanation see page 4 "Taring on the idle power".

## Current sensor (Hall sensor)

The alignment of the WLM-3 to different power levels of motors happens by the choice of the current sensor size or/and by the number of loops through the current sensor hole. E.g., if the current of small motors has to be measured, the phase has to be looped several times through the hole of the sensor (consider the direction of the arrow)

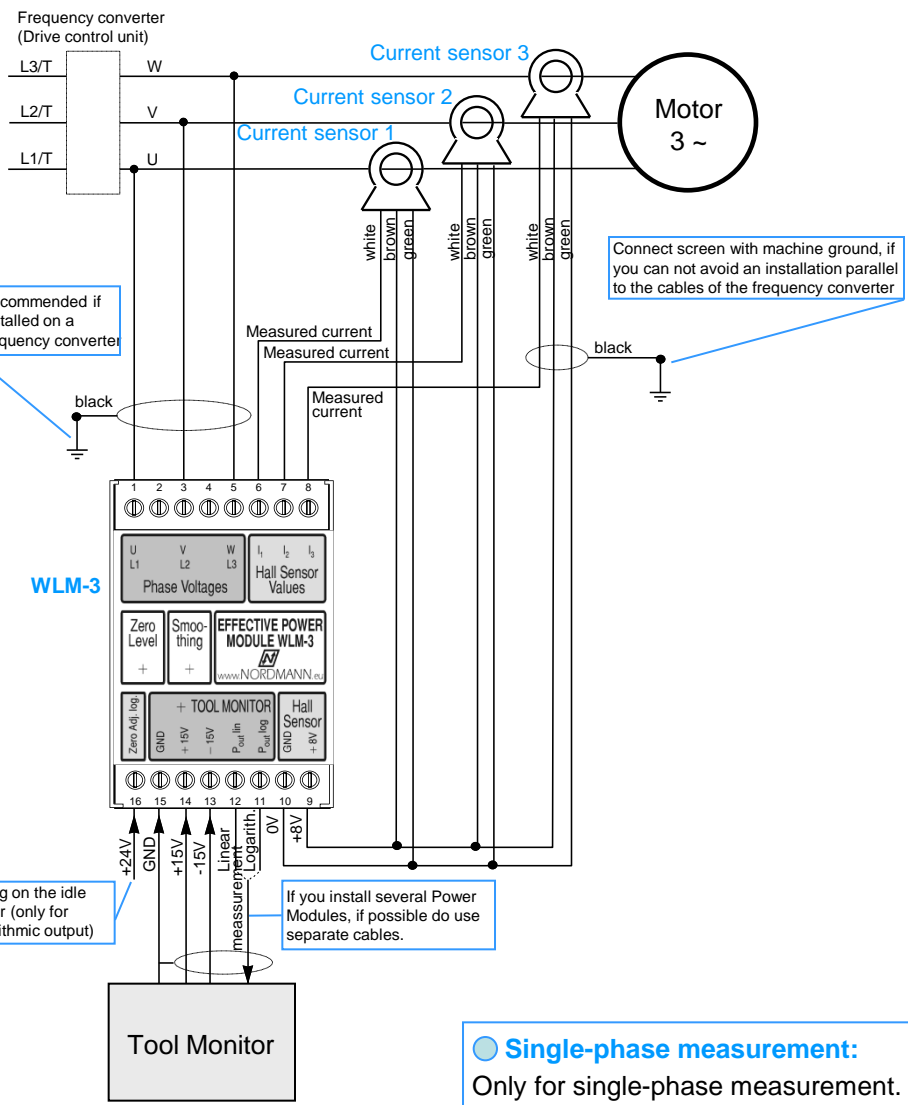
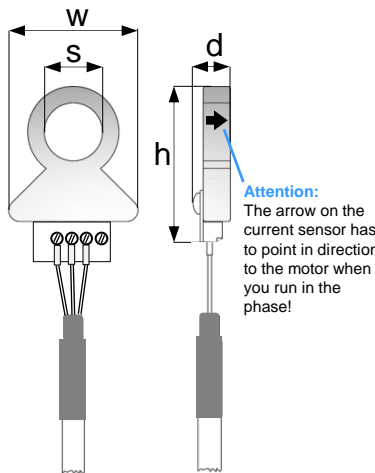

**Single-phase measurement:**  
Only for single-phase measurement.  
Use 1 current sensor.  
(Connect to terminal 6, 9 and 10)

Power [kW] (Use this term for order number)	Dimensions current sensor [mm]			
	s Hole for phase	w width	h height	d depth
1,5/7,5	Ø 11,1	31,4	46,0	16,0
3/15	Ø 15,7	35,0	53,0	25,0
6/30 11/55 20/100	Ø 27,0	63,0	67,0	26,5

Motor power class, based on the effective power of the motor on 100% duty ratio. The measurement sensitivity of the WLM-3, equipped with 3 Hall sensors, is only for the linear measurement output (Terminal 12) if only on time a phase is run into each of the 3 Hall sensors.

Current sensor Power [kW]	Sensitivity S [V/A]	Measurement range [V]	Resulting Sensitivity of the WLM-3 [V/kW]
1,5	0,16350	4 ± 3,7	7,676
3,0	0,08100	4 ± 3,7	3,805
6,0	0,03800	4 ± 3,7	1,785
7,5	0,03270	4 ± 3,0	1,535
11,0	0,02150	4 ± 3,7	1,010
15,0	0,01620	4 ± 3,0	0,761
20,0	0,01150	4 ± 3,7	0,540
30,0	0,00760	4 ± 3,0	0,357
55,0	0,00430	4 ± 3,0	0,202
100,0	0,00230	4 ± 3,0	0,108

## Circuitboard drawing Jumper settings

-  Jumper J1  
for measurement amplification

Plugged = No amplification (**default**)  
Unplugged = amplification of 3

If the measurement value is too low, even with big tools, and the change of the Hall sensor to a smaller size or the increase of the number of loops is not possible, the amplification can be increased in the WLM-3. You have to unplug the jumper behind the front lid, to receive an amplification of 3 (=9,54 dB). This method also amplifies the ground noise of the Hall sensor, so only use it if an other amplification is not possible.

-  Jumper J2 for low pass

ON (2-3) = 8Hz low pass (**default**)  
OFF (1-2) = no low pass filtering

If you have to measure fast or short time measurement changes, you have to unplug the low pass (Jumper position = OFF).

Example:  
- Gap elimination e.g. for grinding  
- Detection on tooth breakage for millingheads or hobbing tools

## Measurement amplification

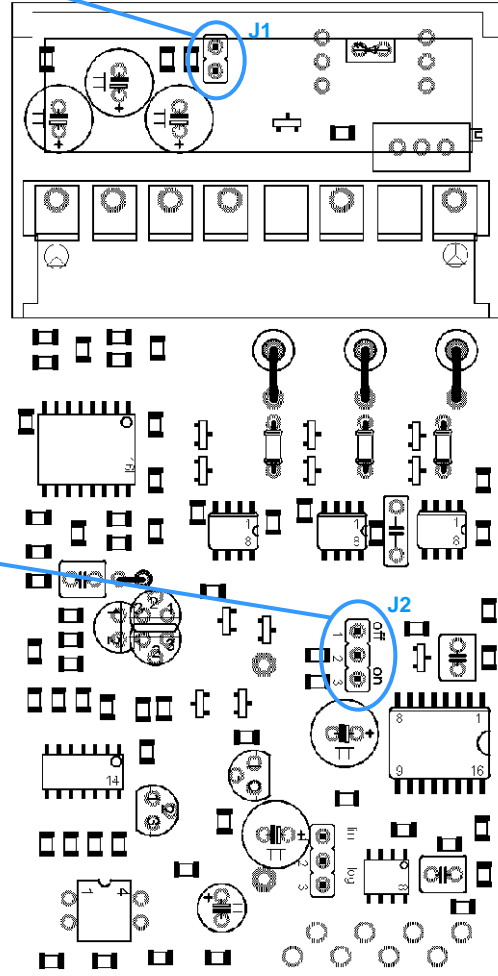

## Low pass

## Converting formulas (power and torque)

The linear power measurement value can be used for an exact quantitative value of the effective power. The internal jumper for the measurement amplification (J1) has to be plugged (default). If you prefer a directly displayed [W] or [Nm], you can change the scale in [W] or [Nm] if you use the linear output, see sensitivity-values [V/kW] for the 3-phase measurement in the table for the current sensors.

### Power measurement with 3 current sensors

$$P = \frac{21,3}{n \times S} \times U_{\text{Meas - lin}} \quad [\text{W}]$$

### Power measurement with 1 current sensor

$$P = 3 \times \frac{21,3}{n \times S} \times U_{\text{Meas - lin}} \quad [\text{W}]$$

### Converting from power To torque

$$M = \frac{P}{2\pi \times n_s} \quad [\text{Nm}]$$

$U_{\text{meas-lin}}$ :	Voltage from linear output (Terminal 12) [V]
$\pi$ :	pi (3,14)
$n$ :	Number of phase loops through the hole of the current sensor
$n_s$ :	Speed of the tool spindle [1/s] or [Hz]
$S$ :	Sensitivity of the current sensor [V/A]
$P$ :	Effective power [W]
$M$ :	Torque [Nm]

### 3-Phase measurement:

(up from serial number 30.001)

Up from serial number 30.001 the WLM-3 consists of a **logarithmic** measurement output (Terminal 11) and parallel a **linear** measurement output (Terminal 12).

The logarithmic measurement output displays small measurement with a higher measurement voltage, therefore increased measurement by worn tools are optically lower. The output voltage lift on terminal 11 lays in between -13 V and +13 V. The Tool Monitor evaluates the area of +1 V = 5 dB and +10 V = 50 dB.

The **linear** measurement output (Terminal 12) also got an output voltage lift in between -13 und + 13 V. The negative area shows the generator mode. The Tool Monitor only evaluates the motor mode, i.e. 0 V to +10 V. However the Tool Monitor SEM-Modul-II can measure input voltages from -10 V to + 10 V, i.e. also the generator mode.

#### **Taring on the idle power**

If the heating of the motor has got a reflection on the level of the measurement curve, you should tare on the idle power before there will be a contact between tool and workpiece. For the measurement from the **logarithmic** output (Terminal 11) the taring in the WLM-3 is possible as follows:

In the moment of generating a 24 V signal to terminal 16, the current measurement will be saved and subtracted from the following measurement, as long as the 24 V signal is on. As A signal you can use e.g. the „Cut active“ (S.a.) signal from the Tool Monitor. Only if the run up of the drive is completed to idle power speed you can generate the 24 V signal. You can recognize that you have reached idle power if the power measurement curve is on a constantly horizontal level. The smoothing of the measurement with the „Smoothing“ trimmer is advantageously for a constantly evaluation of the idle power.

The generated linear measurement output (0-10 V) on terminal 12 has to be subtracted to zero at the Tool Monitor. The advantage is, that you can chose an area to average the idle power from the beginning of the cut („Cut active“) to the beinning of the operation. The adjustment of this area can be done graphically using two vertical lines on the display of the Tool Monitor (see chapter „Digital zero adjust“ in the manual for the SEM-Modul, SEM-Profibus and SEM-Profibus-Micro).

**Primary in connection with the Tool Monitor SEM-Modul you should use the linear power measurement, while with the forerunner model SEM-68000 you only evaluate the logarithmic power measurement.**

### Single-Phase measurement:

The Effective Power Modul WLM-3, may for reasons of easier installation and to spare two Hall sensors, run with only one current sensor (Hall sensor) on the phase of an AC motor. However that brings the disadvantage that the curve become rough and that might be troublesome for smaller tools. If that is not the case and the requirements for a high reaction speed of the measurement for fast and quick changing power changes (tool breakage, detecting of missing tooth of milling tools, gap elimination) is not necessary, you can measure a single phase (see diagram). The measurement is 3 times lower than with the 3-phase method. You can compensate this, if you unplug the jumper (J1) behind the front lid, that creates an amplification of 3 (see „circuit board“).

#### **Order number:**

WLM-3            7 . 3 . 2  
Current sensor 7 . 1 . XX

kW-value of the  
current sensor